

This sheet was in a box with parts for  
sprayer pump 12 July 1968



# THE PIERCE GOVERNOR COMPANY INC

## UPLAND, INDIANA 46989

### INSTALLATION INSTRUCTIONS

#### PIERCE GOVERNOR FOR GRAVELY TRACTOR INSTALLATION

##### GENERAL INFORMATION

The Governor functions to adjust the flow of fuel through the Carburetor automatically as the work load demands. It does this by action of governor weights: as the engine tends to slow down due to work load, the weights automatically move a lever which in turn exerts pressure on the Carburetor Bellcrank. This action opens the Bellcrank and allows more fuel to reach the engine. Conversely, when engine RPM increases due to a lighter work load, the Governor moves the Bellcrank to decrease the flow of fuel.

The Pierce Governor, as all governors, is set to operate within a certain range of engine RPM. The Gravelly Tractor develops maximum horsepower under load at about 2600 RPM. It is the function of the Governor to feed the fuel automatically so the engine RPM will remain at the level that develops maximum horsepower.

However, once the engine is loaded above a certain point, the Carburetor is "wide open". This means it is feeding all the fuel possible to the engine. Thus, it is entirely possible to stall the Tractor, even when Governor-equipped, simply because the limit of engine capacity has been reached. This is not any fault of the Governor.

Faulty installation and adjustment of the Governor will allow the engine to operate at excessive RPM, or not allow the engine to idle, etc. Therefore, it is most important that these instructions be followed carefully and thoroughly.

##### LUBRICATION INSTRUCTIONS

The Governor is lubricated at the factory. Additional lubrication is not required until 1,000 hours of Engine Operation or a period of time not to exceed two years. While PIERCE recommends only the Factory Lubricant which has been thoroughly tested and approved, it is permissible to service the Governor with motor oil 30 weight summer or 10 weight winter, plus checking the oil level daily.

##### INSTALLATION INSTRUCTIONS

1. Install Governor on Governor mounting bracket. (Figure 1)
2. Install Governor with Governor mounting bracket to Tractor. (Figure 1)
3. Check alignment of Belt and Governor Pulley. Bend Bracket until Governor Pulley is absolutely straight and square with Fan Belt.

4. Adjust Bracket to make Governor Pulley bear firmly on Fan Belt. Avoid excessive Belt pressure.
5. Assemble the Governor Control Bracket and Arm (1 and 2 in Figure 2). The Governor Control Arm should move easily with very light pressure.
6. Insert the Governor Control Link (3 in Figure 2) into the hole in the Governor Control Arm, extending it toward the Governor Lever.
7. Mount Bellcrank (4 in Figure 2) to Carburetor, discarding the old Bellcrank. Mount so there is equal travel between a vertical line and wide open, and a vertical center line and closed. Then just barely "crack" the Bellcrank away from the wide open stop with a .020" feeler gauge.
8. Hold the Bellcrank in the wide open position (Figure 3) and the Governor Lever at its stop toward the Tractor. Fit Throttle Linkage Rod (5 in Figure 2) from Bellcrank to the end of the Governor Lever. The Throttle Linkage Rod may be bent slightly. The Rod must fit freely and firmly in place without binding or strain. Attach Rod to Bellcrank with small Clip provided.
9. Insert the Governor Spring (6 in Figure 2) into the center hole in the Governor Lever. Hook Spring into the slot in the Governor Control Link.
10. Bend the Throttle Wire  $\frac{3}{8}$ " from the end in a downward position so the end is vertical to the ground. Insert into hole in the Governor Arm and then bend into a horizontal position to the ground. Test to make sure Throttle Wire can move freely through its entire travel without binding the Throttle Wire portion that is within the Governor Arm. Adjust as required.
11. Start the Tractor. With Throttle Lever closed, adjust the Carburetor Idling screw until the Tractor is idling satisfactorily, being sure the Idle Screw contacts the stop while this is being done.
12. The purpose of the holes in the Governor Lever is to control the sensitivity of response by the Governor to the engine load. If the Governor is not responding quickly enough to load, move the Spring one hole closer to the Governor. If it is responding too quickly, move the Spring one hole away, continuing until it responds satisfactorily.

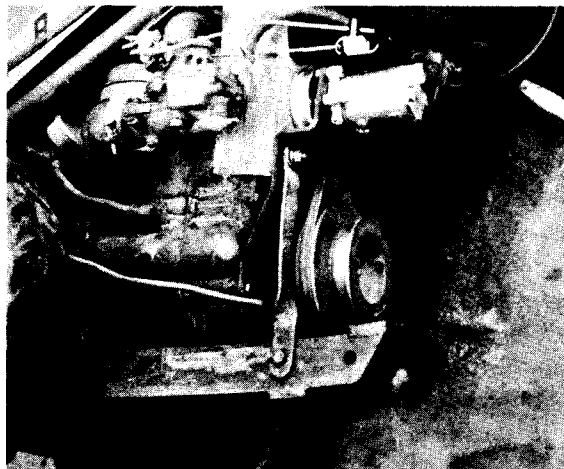

Figure 1

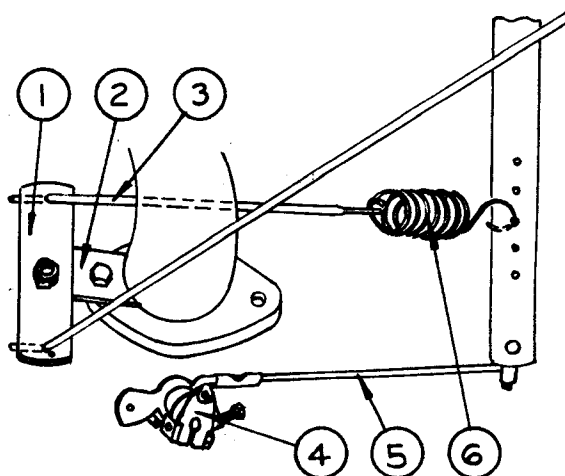

Figure 2

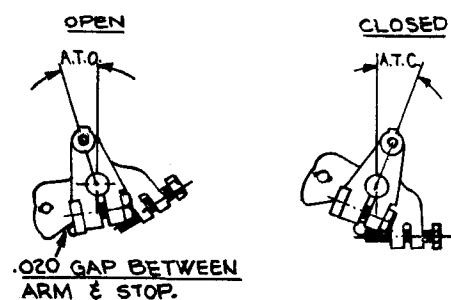

Figure 3