



Complete Repair Kit - Steering Cylinder - DA-150-075-K-0-0
 Best Metal Products (616) 942-7141 (44583)
 Vendor # 1863 4W246

PROFESSIONAL 24-G TRACTOR ILLUSTRATED PARTS LIST

- 46005 - Complete Trans For 24-G
- 48587 - Hyd Spc For Valve
- 50786 - Pump Shft
- ~~48269 - Pur. Steg. Seal Kit~~
- (44863 - Column Brg) See 7173 Pur Steg
- 44864 - Cap Also 30-H Same Pur Steg

PS Seal Kit ROSS
 589 006

TO CONTINUE ITS PROGRAM OF QUALITY AND DESIGN IMPROVEMENTS, THE MANUFACTURER RESERVES THE RIGHT TO CHANGE SPECIFICATIONS, DESIGNS AND PRICES WITHOUT NOTICE AND WITHOUT INCURRING OBLIGATION. THE MANUFACTURER ALSO RESERVES THE RIGHT TO SHIP WITHOUT NOTICE AND WITHOUT INCURRING OBLIGATION.

 **GRAVELLY**®

TABLE OF CONTENTS

	<u>Page</u>
Transmission	1
Number One Shaft - Forward Clutch	2
Number Two Shaft - Reverse Clutch	3
Number Three Shaft - 3rd and 4th Gear	4
Number Four Shaft - Idler	4
Number Five Shaft - 1st and 2nd Gear	4
Number Six Shaft - Brake/Sliding Gear	6
Number Seven Shaft - Pinion/Final Drive	6
Number Eight Shaft - Differential Assembly	8
Number Nine Shaft - PTO Clutch	8
Number Ten Shaft - PTO Drive Assembly	10
Number Eleven - Fwd-Rev Clutch Assembly	10
Number Twelve - Transmission Case Assembly	12
Number Thirteen - Transmission Cover Assembly	14
Number Fourteen - PTO Clutch Assembly	14
Frame	16
Hood and Rear Deck	18
Rear Hitch	20
Front and Rear Wheels	21
Hydraulic System	22
Steering	24
Direction Control	26
Transmission Controls	28
Brake Linkage	30
Fuel and Exhaust System	32
Electrical System	34

TRANSMISSION

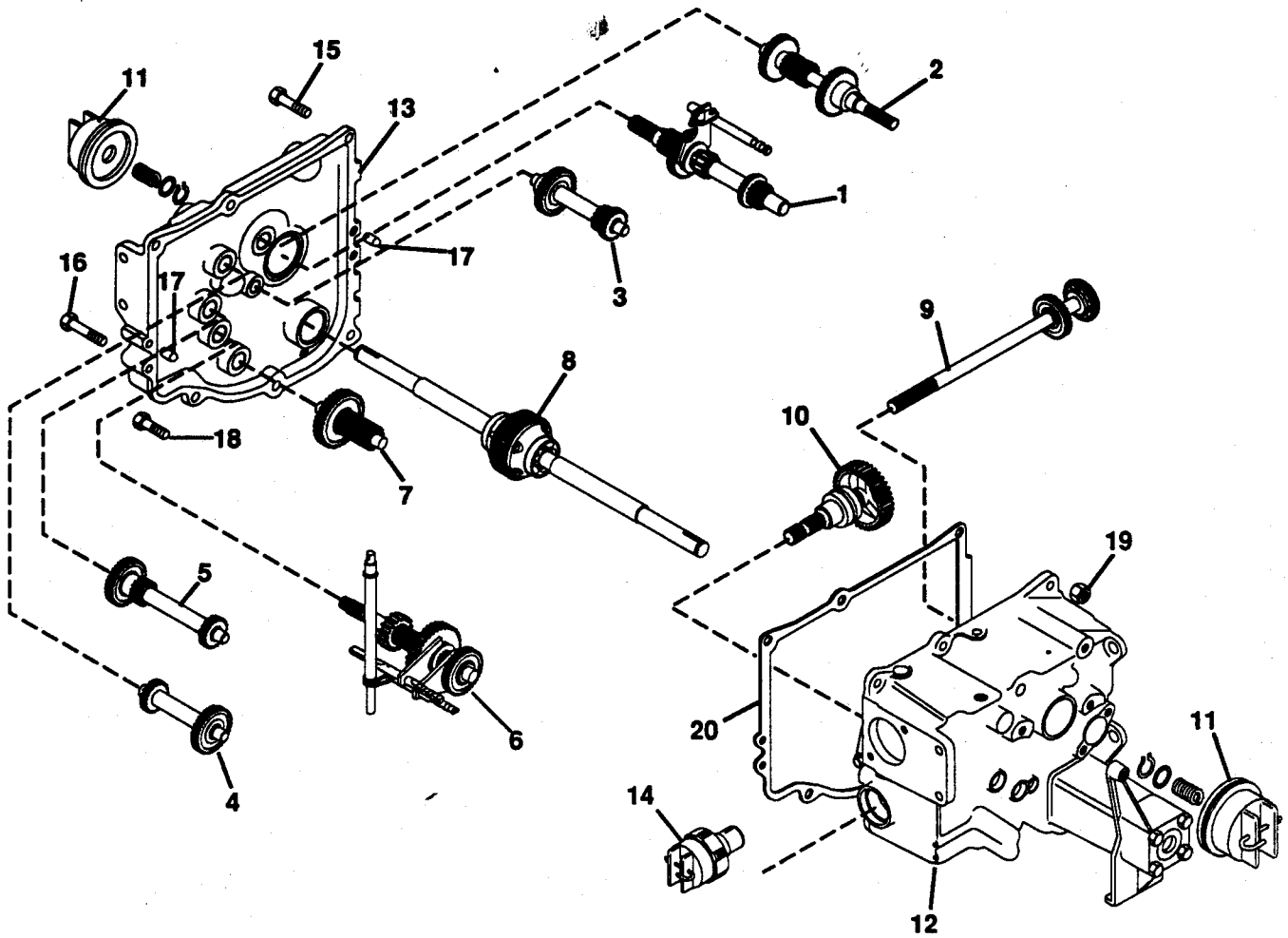

ITEM NO.	PART NO.	QTY.	DESCRIPTION	ITEM NO.	PART NO.	QTY.	DESCRIPTION
1			No. 1 Shaft, Forward Clutch	11			No. 11, Fwd-Rev Clutch Asm.
2			No. 2 Shaft, Reverse Clutch	12			No. 12, Transmission Case Asm.
3			No. 3 Shaft, 3rd and 4th Gear	13			No. 13, Transmission Cover Asm.
4			No. 4 Shaft, Idler	14			No. 14, PTO Clutch Asm.
5			No. 5 Shaft, 1st and 2nd Gear	15	180130	2	Bolt, Hex 3/8-16x2.00
6			No. 6 Shaft, Brake-Sliding Gear	16	180132	2	Bolt, Hex 3/8-16x2.25
7			No. 7 Shaft, Pinion-Final Drive	17	18089	2	Pin, Dowel .375x.625
8			No. 8 Shaft, Differential Asm.	18	180126	4	Bolt, Hex 3/8-16x1.50
9			No. 9 Shaft, PTO Clutch	19	456004	6	Nut, Lock 3/8-16
10			No. 10 Shaft, PTO Drive Asm.	20	18027	1	Gasket, Transmission Cover

NUMBER ONE SHAFT - FORWARD CLUTCH

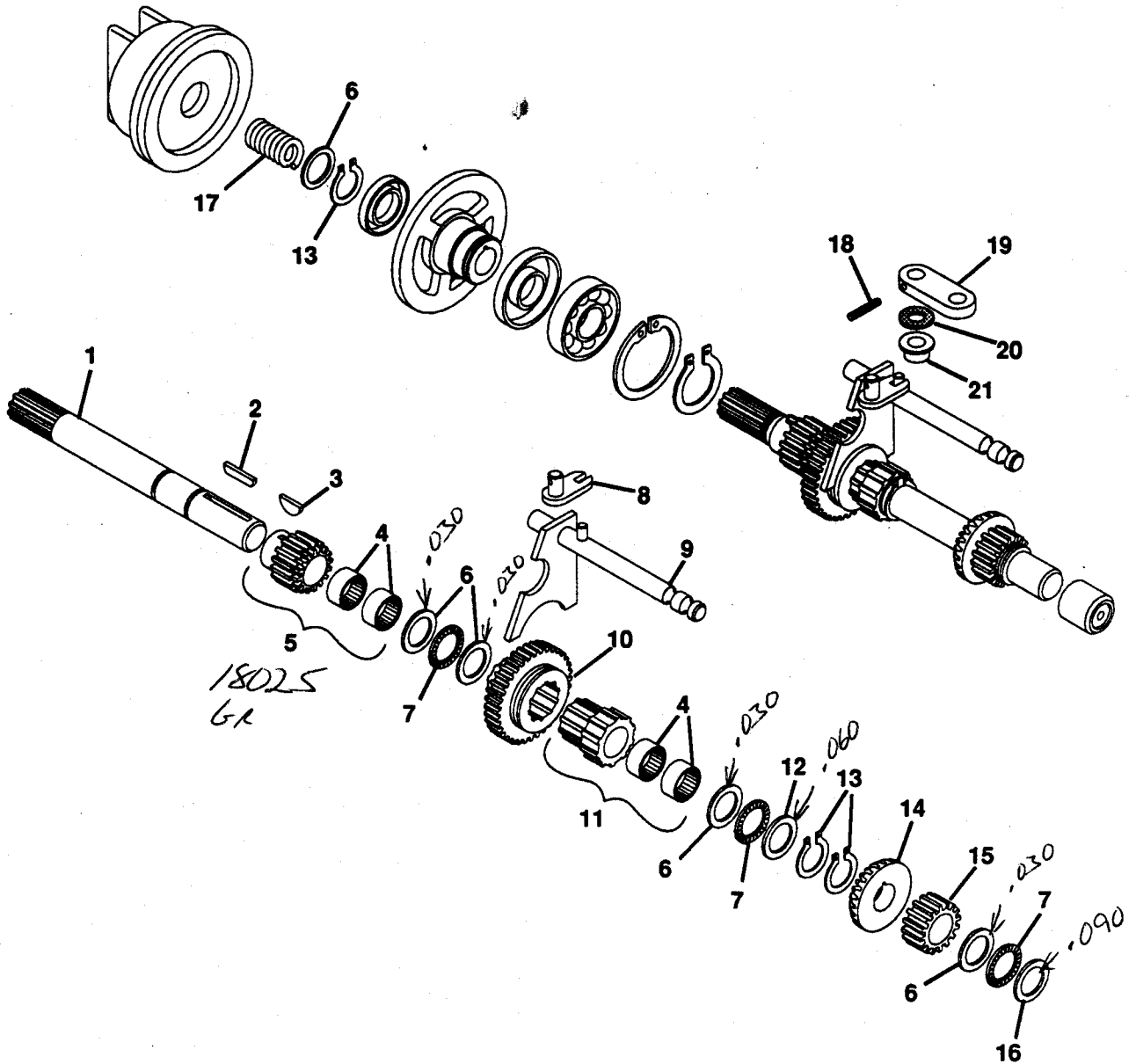

ITEM NO.	PART NO.	QTY.	DESCRIPTION	ITEM NO.	PART NO.	QTY.	DESCRIPTION
1	46371	1	Shaft, Splined Fwd Clutch	12	6742	1	Race, .060 Bearing Thrust
2	117989	1	Key, Woodruff .188x1.25 Hrd #19	13	11135	3	Ring, Retaining .750 Shaft
3	431787	1	Key, Woodruff .188x.625 Hrd #61	14	45585	1	Gear, Bevel
4	17949	4	Bearing, Needle .75x1x.50	15	18003	1	Gear, 10 DP 16 Teeth x .750 Std.
5	46330	1	Gear and Bearing Assembly	16	14998	1	Race, Thrust .752x1.240x.095
6	11223	5	Race, Brg Thrust .752x1.240x.030	17	20444	1	Spring, Comp. 1.0x.80x36 lb/in
7	6741	3	Bearing, Thrust .752x1.240x.078	18	421202	1	Pin, Spring .188x1.00
8	17926	1	Weldment, Shifter	19	17929	1	Arm, Shifter
9	20755	1	Weldment, Shift Rail	20	21141	1	Washer, Felt
10	18011	1	Gear, Spur	21	17925	1	Bushing, 2-Speed
11	18007	1	Gear and Bearing Assembly				

NUMBER TWO SHAFT - REVERSE CLUTCH

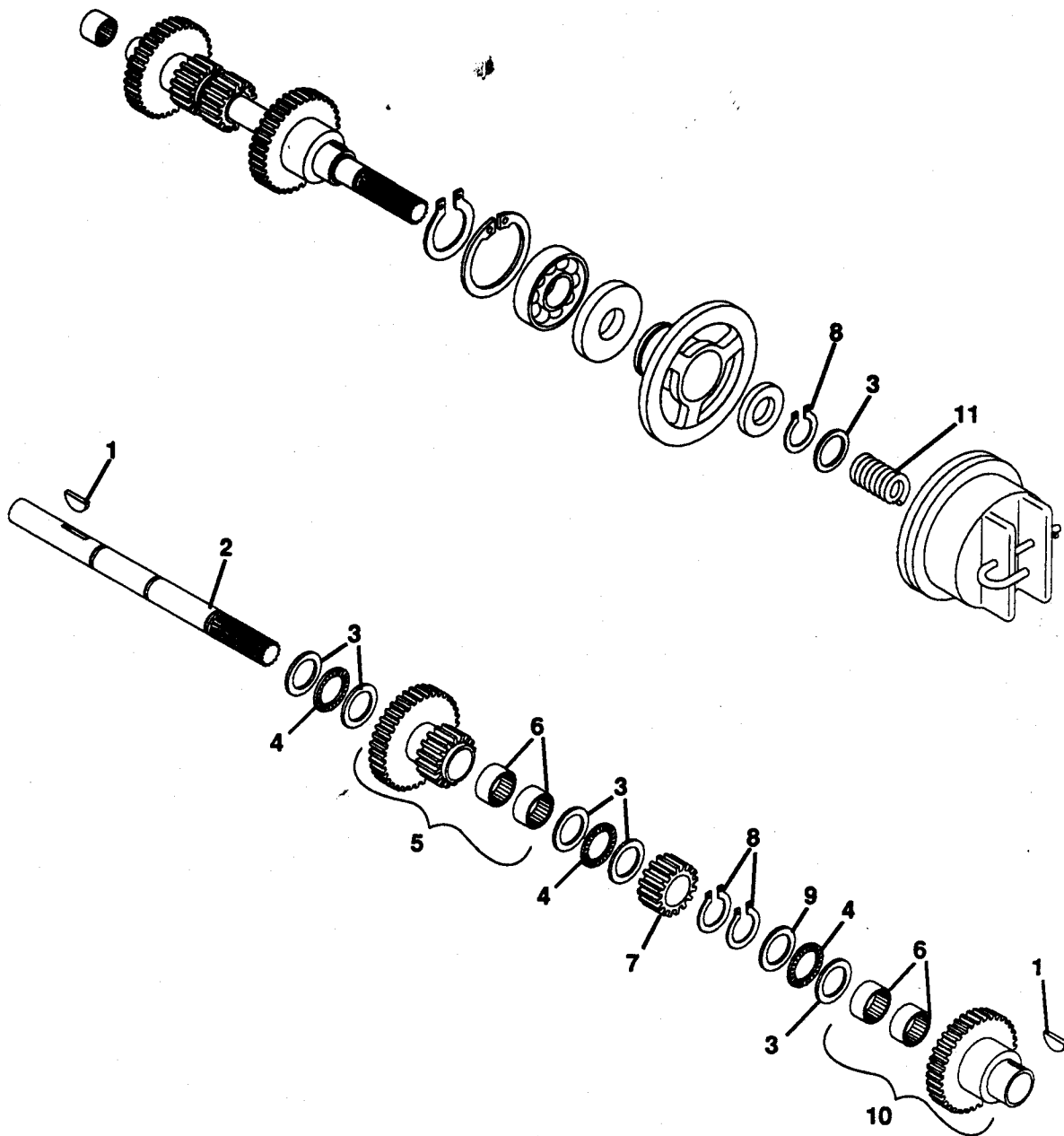

ITEM NO.	PART NO.	QTY.	DESCRIPTION	ITEM NO.	PART NO.	QTY.	DESCRIPTION
1	431787	2	Key, Woodruff .188x.625 Hrd #61	7	18003	1	Gear, 10 DP 16 Teeth x .750 Std.
2	34730	1	Shaft, Splined Rev Clutch	8	11135	3	Ring, Retaining .750 Shaft
3	11223	6	Race, Brg Thrust .752x1.240x.030	9	6742	1	Race, .060 Bearing Thrust
4	6741	3	Brg, Needle Thrust .752x1.24x.078	10	17947	1	Assembly, Reverse Gear and Brg
5	18020	1	Gear, Idler Assembly	11	20444	1	Spring, Comp. 1.0x.80x36 lb/in
6	17949	4	Bearing, Needle .75x1x.50				

NUMBER THREE SHAFT - 3RD AND 4TH GEAR

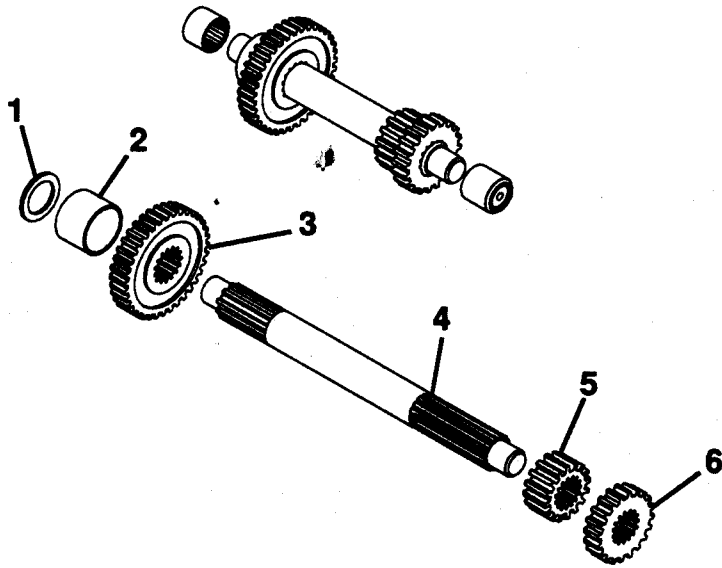

NUMBER FOUR SHAFT - IDLER

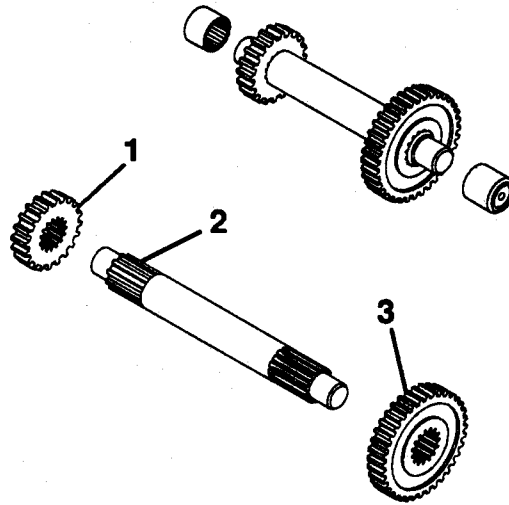

NUMBER FIVE SHAFT - 1ST AND 2ND GEAR

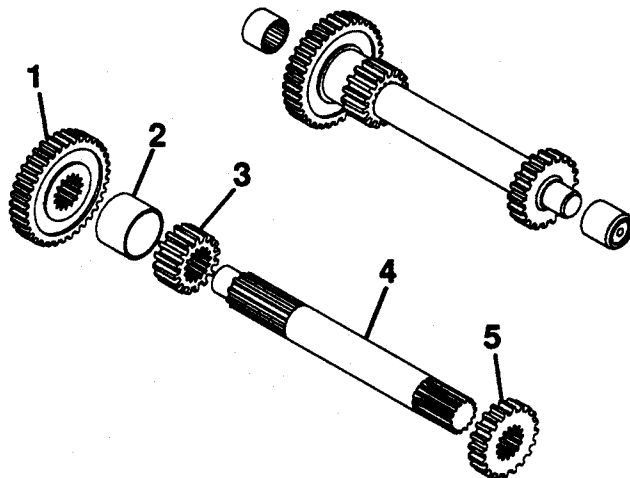

NUMBER THREE SHAFT - 3RD AND 4TH GEAR

ITEM NO.	PART NO.	QTY.	DESCRIPTION	ITEM NO.	PART NO.	QTY.	DESCRIPTION
1	18000	1	Brg, Thrust Race .627x1.115x.094	4	17997	1	Shaft, Splined
2	17999	1	Spacer, 1.027x1.125x.457	5	17992	1	Gear, 10 DP 16 Teeth x .750
3	19535	1	Gear	6	15118	1	Gear, 10 DP 20 Teeth x .600

NUMBER FOUR SHAFT - IDLER

ITEM NO.	PART NO.	QTY.	DESCRIPTION	ITEM NO.	PART NO.	QTY.	DESCRIPTION
1	15118	1	Gear, 10 DP 20 Teeth x .600	3	15115	1	Gear, 10 DP 30 Teeth x .500
2	17995	1	Shaft, Splined				

NUMBER FIVE SHAFT - 1ST AND 2ND GEAR

ITEM NO.	PART NO.	QTY.	DESCRIPTION	ITEM NO.	PART NO.	QTY.	DESCRIPTION
1	15115	1	Gear, 10 DP 30 Teeth x .500	4	17989	1	Shaft, Splined
2	17993	1	Spacer, 1.027x1.125x.550	5	15118	1	Gear, 10 DP 20 Teeth x .600
3	17992	1	Gear, 10 DP 16 Teeth x .750				

NUMBER SIX SHAFT - BRAKE/SLIDING GEAR

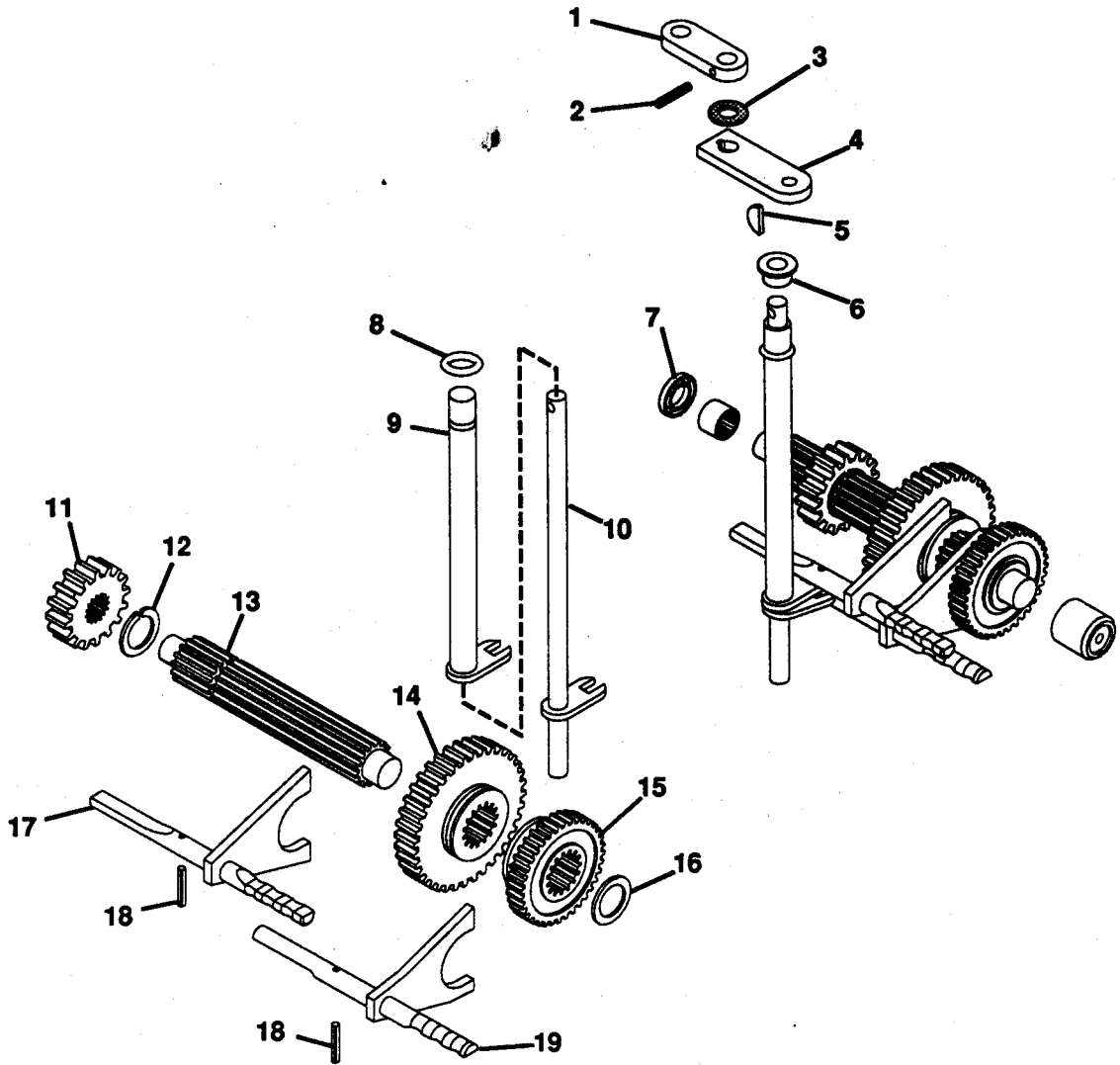

NUMBER SEVEN SHAFT - PINION/FINAL DRIVE

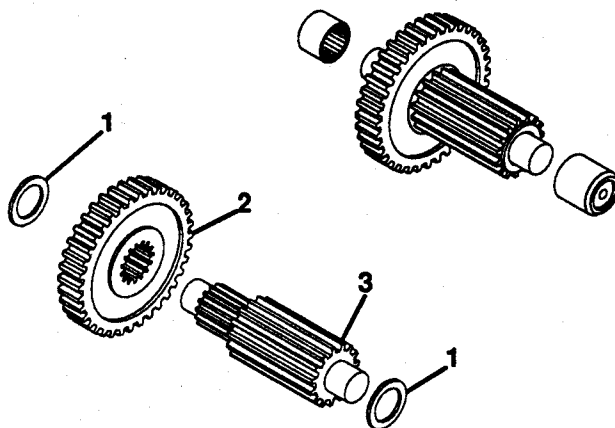

NUMBER SIX SHAFT - BRAKE/SLIDING GEAR

ITEM NO.	PART NO.	QTY.	DESCRIPTION	ITEM NO.	PART NO.	QTY.	DESCRIPTION
1	17945	1	Arm, Shifter	11	14988	1	Gear, 8 DP 16 Teeth x .850
2	421202	1	Pin, Spring .188x1.000	12	14987	1	Ring, Retaining 1.00 Shaft
3	21141	1	Washer, Felt (Special for Trans.)	13	35438	1	Shaft, Slide Gear
4	17944	1	Arm, Shifter	14	14989	1	Gear, Sliding 10 DP 36 Teeth x .59
5	271089	1	Key, Woodruff .125x.375 Hard	15	14995	1	Gear, Sliding 10 DP 30 Teeth x .59
6	17943	1	Bushing, .756x1.125x.75	16	14998	1	Race, Brg Thrust .752x1.240x.095
7	15137	1	Seal, Oil .750x1.254x.188	17	20761	1	Wldmt, Rail Shift Fork 1&3 Range
8	18018	1	O-Ring, 5/8x3/4x1/16	18	456390	2	Pin, Spring .25x.75
9	17940	1	Weldment, 1st and 3rd Shifter	19	20762	1	Wldmt, Rail Shift Fork 2&4 Range
10	17937	1	Weldment, 2nd and 4th Shifter				

NUMBER SEVEN SHAFT - PINION/FINAL DRIVE

ITEM NO.	PART NO.	QTY.	DESCRIPTION	ITEM NO.	PART NO.	QTY.	DESCRIPTION
1	19340	2	Race, Brg Thrust 1.002x1.552x.03	3	17986	1	Pinion, Final Drive
2	17987	1	Gear, 8 DP 30 Teeth x .750				

NUMBER EIGHT SHAFT - DIFFERENTIAL ASSEMBLY

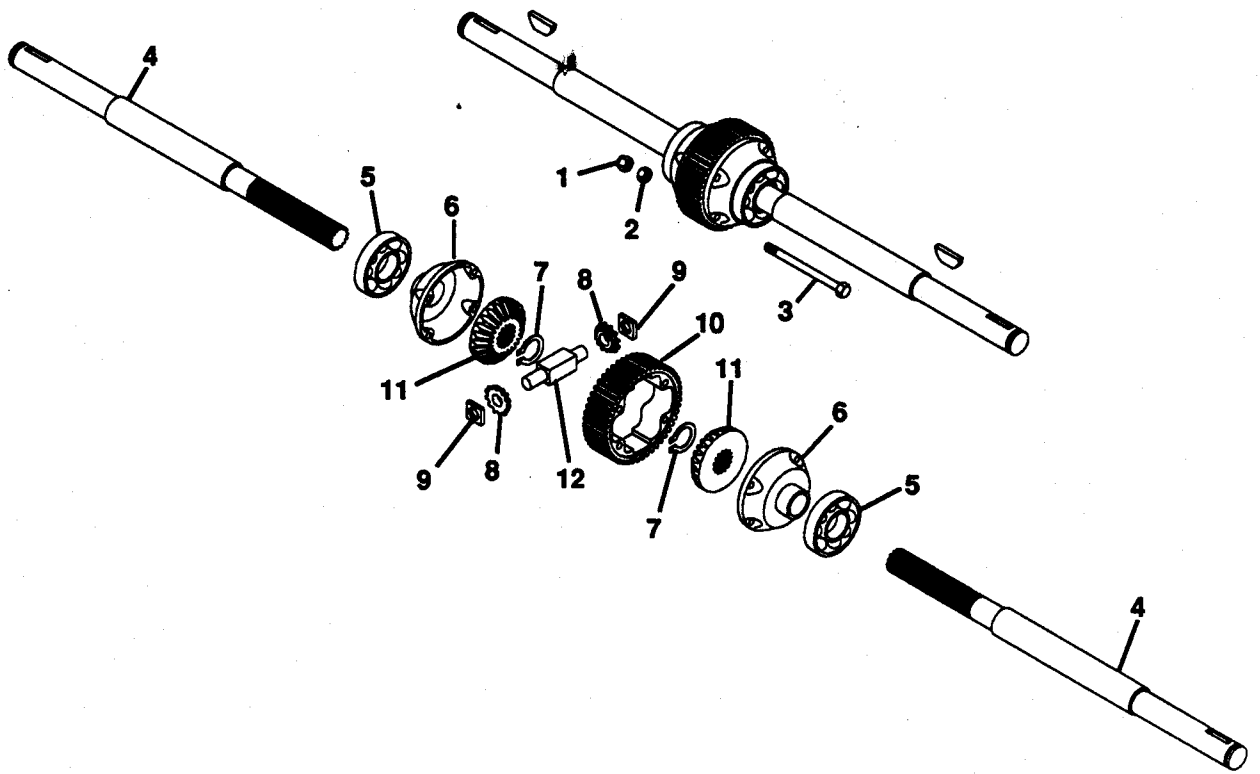

NUMBER NINE SHAFT - PTO CLUTCH

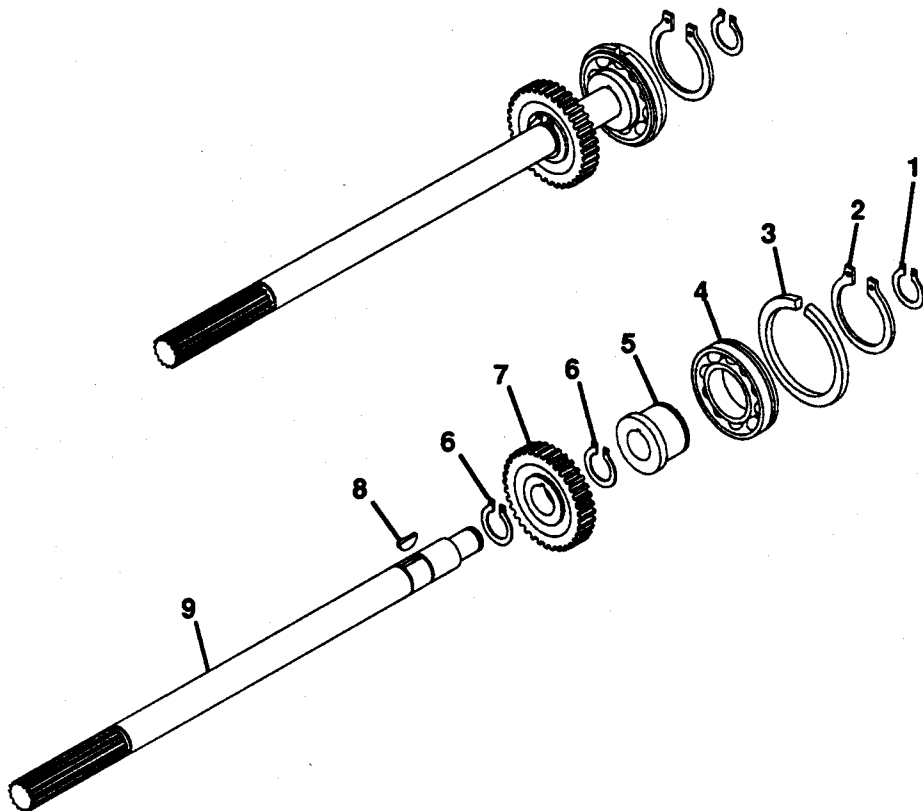

NUMBER EIGHT SHAFT - DIFFERENTIAL ASSEMBLY

ITEM NO.	PART NO.	QTY.	DESCRIPTION	ITEM NO.	PART NO.	QTY.	DESCRIPTION
1	419455	4	Nut, Lock 5/16-18	7	21608	2	Ring, Retaining 1.250 Sft Heavy
2	20514	4	Nut, Hex 5/16-18 Grade-8	8	19952	2	Pinion, Bevel
3	23712	4	Bolt, Hex 5/16-18x2.75 Grade-8	9	46376	2	Block, Drive
4	46011	2	Axle, Bevel Gear Differential	10	23531	1	Gear, Final Drive
5	46014	2	Bearing, Ball	11	46012	2	Gear, Bevel
6	46013	2	Cap, Differential End	12	19954	1	Pin, Spider Pinion

NUMBER NINE SHAFT - PTO CLUTCH

ITEM NO.	PART NO.	QTY.	DESCRIPTION	ITEM NO.	PART NO.	QTY.	DESCRIPTION
1	11135	1	Ring, Retaining .750 Shaft	6	21557	2	Ring, Retaining .984 Shaft
2	23523	1	Ring, Retaining	7	35441	1	Gear, PTO Cross Shaft
3	17966	1	Ring, Retaining	8	124549	1	Key, Woodruff .187x.750 Hrd #9
4	17967	1	Bearing, Ball 1.378x2.440x.551	9	42635	1	Shaft, PTO
5	35491	1	Adapter, PTO Bearing				

NUMBER TEN SHAFT - PTO DRIVE ASSEMBLY

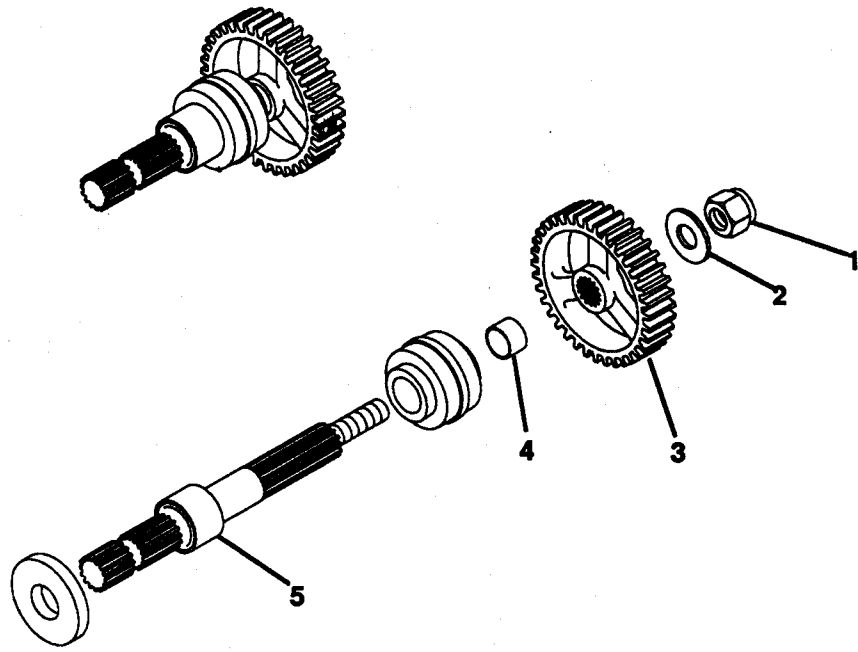

NUMBER ELEVEN - FWD-REV CLUTCH ASSEMBLY

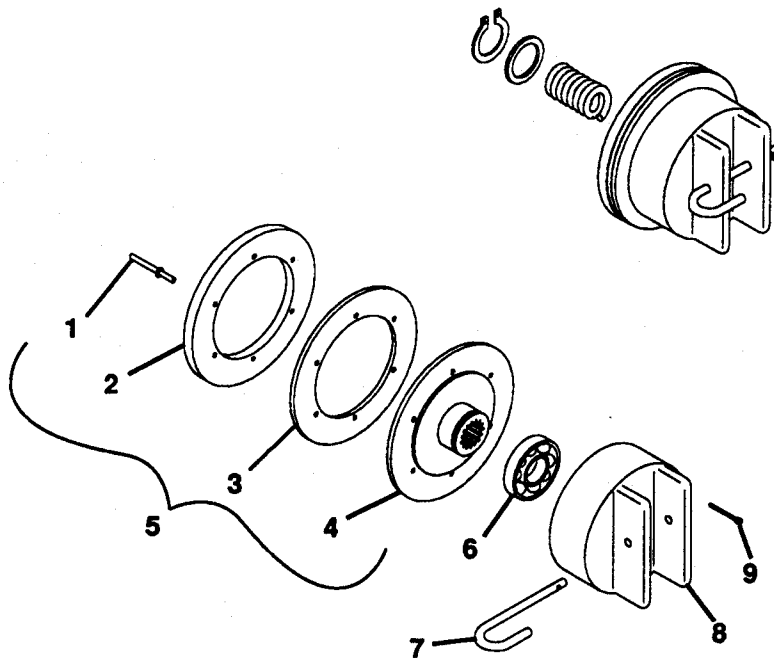

NUMBER TEN SHAFT - PTO DRIVE ASSEMBLY

ITEM NO.	PART NO.	QTY.	DESCRIPTION	ITEM NO.	PART NO.	QTY.	DESCRIPTION
1	414075	1	Nut, Lock 5/8-11	4	17924	1	Spacer, 1.060x1.375x.450
2	33845	1	Washer, Flat .687x1.312x.122	5	19538	1	Shaft, PTO
3	45114	1	Gear, PTO 34 Tooth				

NUMBER ELEVEN - FWD-REV CLUTCH ASSEMBLY

ITEM NO.	PART NO.	QTY.	DESCRIPTION	ITEM NO.	PART NO.	QTY.	DESCRIPTION
1	44141	1	Rivet, Steel (Bag of 50)	6	35330	2	Bearing, Ball 1.574x3.149x.708
2	40692	2	Lining, Clutch	7	35681	2	Pin, Clutch Spring
3	42481	2	Ring, Clutch	8	34734	2	Trunnion, Fwd-Rev Clutch
4	42484	2	Disc, Clutch	9	121223	2	Pin, Cotter .06x.75
5	42482	2	Assembly, Clutch and Ring				

NUMBER TWELVE - TRANSMISSION CASE ASSEMBLY

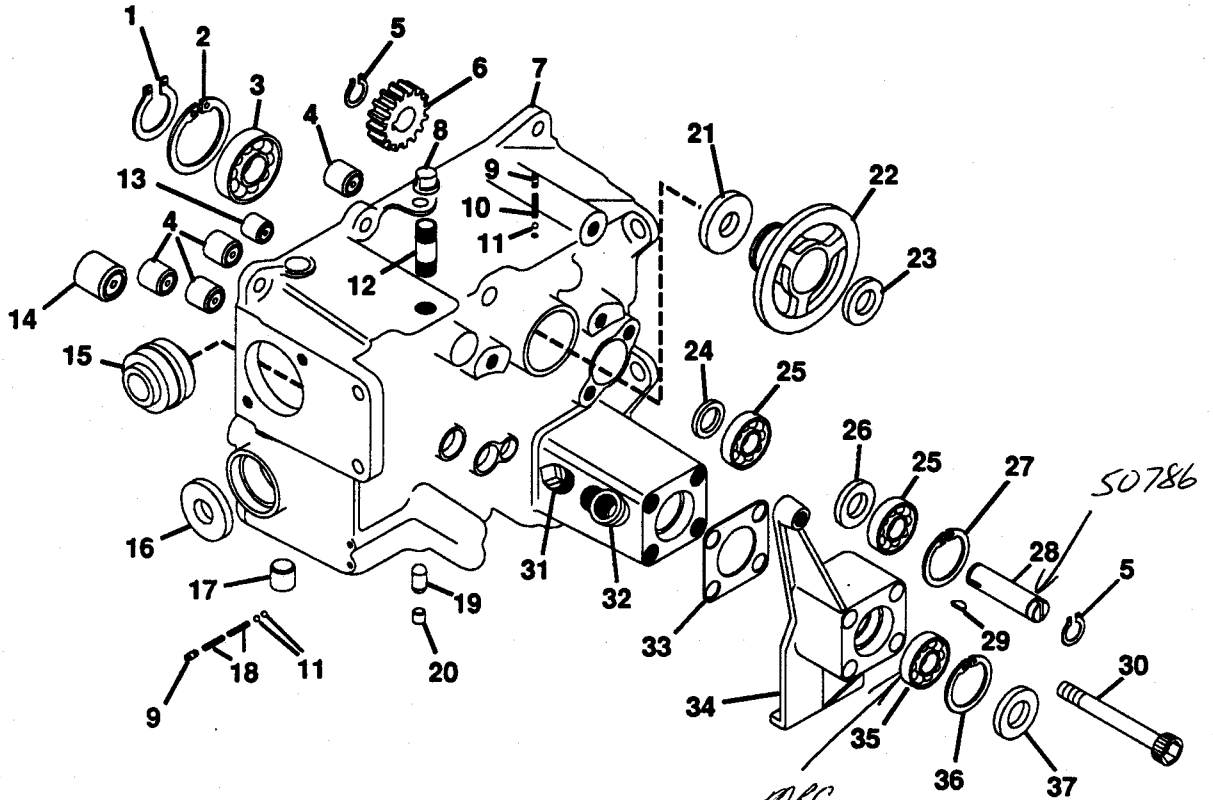

NUMBER TWELVE - TRANSMISSION CASE ASSEMBLY

ITEM NO.	PART NO.	QTY.	DESCRIPTION	ITEM NO.	PART NO.	QTY.	DESCRIPTION
1	17919	1	Ring, Retaining 1.969 Shaft	20	421743	1	Plug, Cup 3/8
2	18872	1	Ring, Retaining 3.156 Bore	21	17917	2	Seal, Oil 2.250x3.005x.375
3	17915	1	Bearing, Ball 1.968x3.149x.629	22	18024	1	Hub, Clutch
4	17913	4	Bearing, Needle .75x1x.75	23	18035	1	Seal, Oil .75x1.625x.25
5	18809	2	Ring, Retaining .594 Shaft	24	18807	1	Spacer, .276x.620x.750
6	18808	1	Gear, Hydraulic Pump	25	12626	2	Bearing, Ball .590x1.378x.433
7	46099	1	Assembly, Transmission Case	26	18798	1	Spacer .620x.750x.364
8	19472	1	Cap, Pipe 1/2 NPT	27	18799	1	Ring, Retaining 1.378 Bore
9	103877	3	Plug, Pipe 1/8	28	18207 50786	1	Shaft, Hydraulic Pump <i>50786</i>
10	24772	1	Spring	29	271089	1	Key, Woodruff .125x.375 Hard
11	274301	5	Ball, Steel 5/16	30	138300	4	Bolt, 1/2-13x3.50 Hex Head Cap
12	121664	1	Nipple, Pipe 1/2x2.5	31	103880	1	Plug, Pipe 1/2
13	17914	1	Bearing, Needle .625x.812x.750	32	108686	1	Elbow, 1/2 90 Degree Street
14	17912	1	Bearing, Needle 1.000x1.250x.75	33	18030	1	Gasket
15	14640	1	Asm, Bearing 1.00x1.98x1.243	34	42976	1	Retainer, Axle Bearing
16	17923	1	Seal, Oil 1.375x2.129x.312	35	18029	1	Bearing, Ball 1.250x2.250x.500
17	17946	1	Plug	36	18812	1	Ring, Retaining .08 Thick
18	17936	4	Spring, Comp. 1.50x.30x26 lb/in	37	18031	2	Seal, Oil Axle
19	18200	1	Pin, Interlock				

